

P2307

S-P2307

16V P-Channel Enhancement-Mode MOSFET

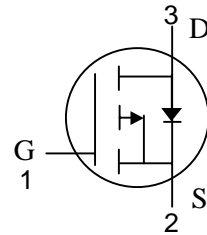
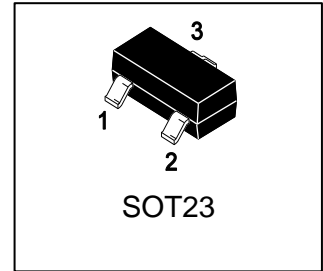

1. FEATURES

- $V_{DS} = -16V$
- $R_{DS(ON)}, V_{GS@-4.5V}, I_{DS@-4.7A} = 70m\Omega$
- $R_{DS(ON)}, V_{GS@-2.5V}, I_{DS@-1A} = 110m\Omega$
- We declare that the material of product compliance with RoHS requirements and Halogen Free.
- S- prefix for automotive and other applications requiring unique site and control change requirements; AEC-Q101 qualified and PPAP capable.
- Advanced trench process technology
- High density cell design for ultra low on-resistance

2. APPLICATIONS

- Simple drive requirement
- Small package outline
- Surface mount device

3. DEVICE MARKING AND ORDERING INFORMATION

Device	Marking	Shipping
P2307	P07	3000/Tape&Reel

4. MAXIMUM RATINGS($T_a = 25^\circ C$)

Parameter	Symbol	Limits	Unit
Drain-Source Voltage	V_{DSS}	-16	V
Gate-to-Source Voltage	V_{GS}	± 8	V
Continuous Drain Current(Note 3)	ID	$T_A = 25^\circ C$	-4.7
		$T_A = 70^\circ C$	-3.3
Pulsed Drain Current(Note 1)	IDM	-20	A

5. THERMAL CHARACTERISTICS

Parameter	Symbol	Limits	Unit
Total Power Dissipation	PD	$T_A = 25^\circ C$	1.1
		$T_A = 70^\circ C$	0.7
Thermal Resistance, Junction-to-Ambient(Note 3)	$R_{\theta JA}$	110	$^\circ C/W$
Operating Junction and Storage temperature range	T_J, T_{stg}	-55~+150	$^\circ C$



6. ELECTRICAL CHARACTERISTICS (Ta= 25°C)

Characteristic	Symbol	Min.	Typ.	Max.	Unit
Drain–Source Breakdown Voltage (VGS = 0, ID = -250μA)	VBRDSS	-16	-	-	V
Gate Threshold Voltage (VDS = VGS, ID = -250μA)	VGS(th)	-0.6	-0.85	-1.4	V
Drain-Source Leakage Current (VDS = -16V, VGS = 0V)	IDSS	-	-	-1	μA
Gate-Source Leakage Current (VGS = ±8 V, VDS = 0V)	IGSS	-	-	100	nA
Static Drain–Source On–State Resistance(Note 2) (VGS = -4.5V, ID = -4.7A) (VGS = -2.7V, ID = -3.8A) (VGS = -2.5V, ID = -1.0A)	RDS(on)	-	48 63 65	70 100 110	mΩ
Forward Transconductance (VDS = -10V, ID = -4.7A)	gfs	-	10.8	-	S
Input Capacitance (VGS = 0 V, f = 1.0MHz, VDS= -15 V)	Ciss	-	828	-	pF
Output Capacitance (VGS = 0 V, f = 1.0MHz, VDS= -15 V)	Coss	-	75.2	-	
Reverse Transfer Capacitance (VGS = 0 V, f = 1.0MHz, VDS= -15 V)	Crss	-	67.4	-	
Total Gate Charge	(ID = -4.7A, VDS = -10V, VGS = -4.5V)	Qg	-	9.2	nC
Gate-Source Charge		Qgs	-	1.3	
Gate-Drain Charge		Qgd	-	3.3	
Turn-On Delay Time	(VDS = -10V, ID = -1A, RL = 10Ω, VGS = -4.5V, RG = 6.2Ω, tp = 10us)	td(on)	-	18.8	ns
Rise Time		tr	-	26	
Turn-Off Delay Time		td(off)	-	95.6	
Fall Time		tf	-	42	
Max Diode Forward Current	IS	-	-	-1.7	A
Forward Voltage (IS = -1.7A, VGS = 0V)	VSD	-	-	-1.2	V

1. Pulse width limited by Max. junction temperature.

2. Pulse Test: Pulse Width ≤ 300 μs, Duty Cycle ≤ 2.0%.

3. Surface mounted on 1 in² copper pad of FR4 board ; 270°C/W when mounted on min. copper pad.

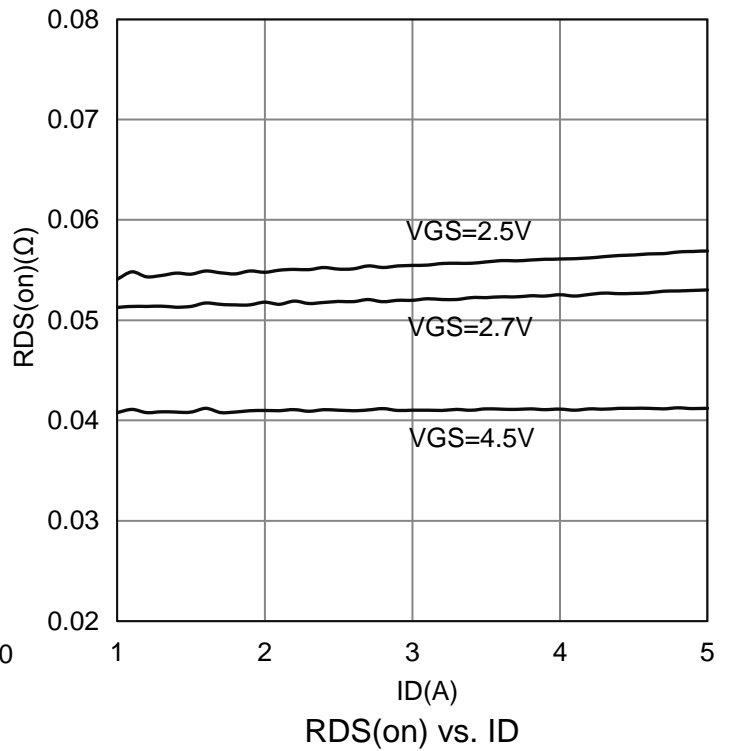
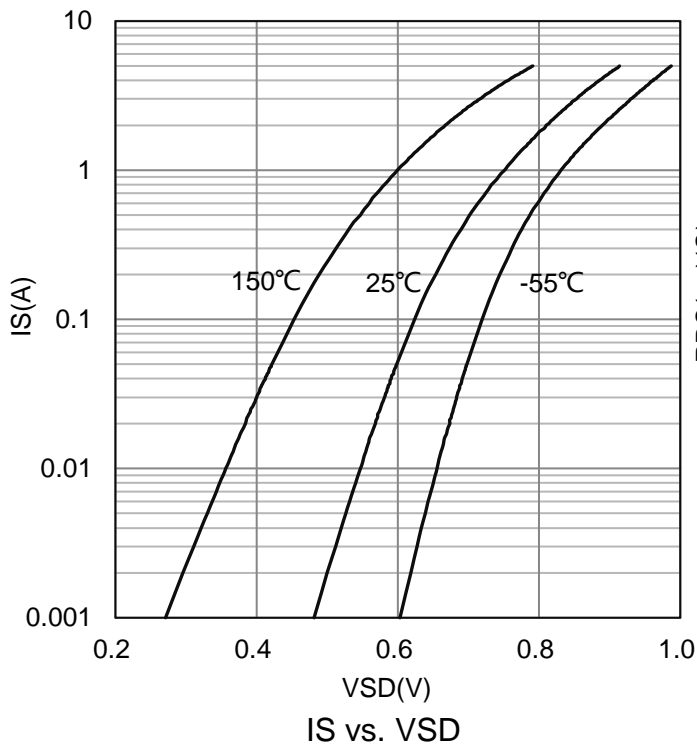
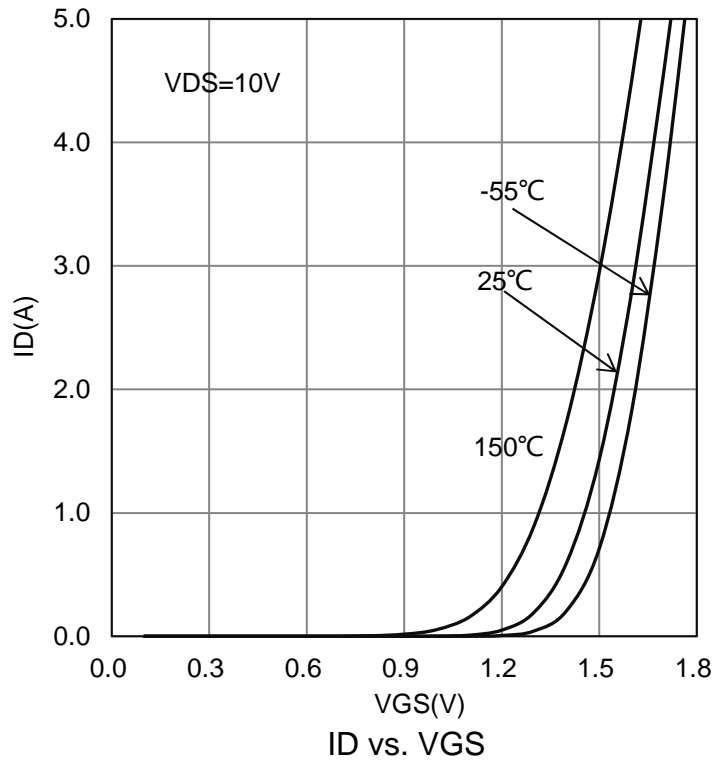
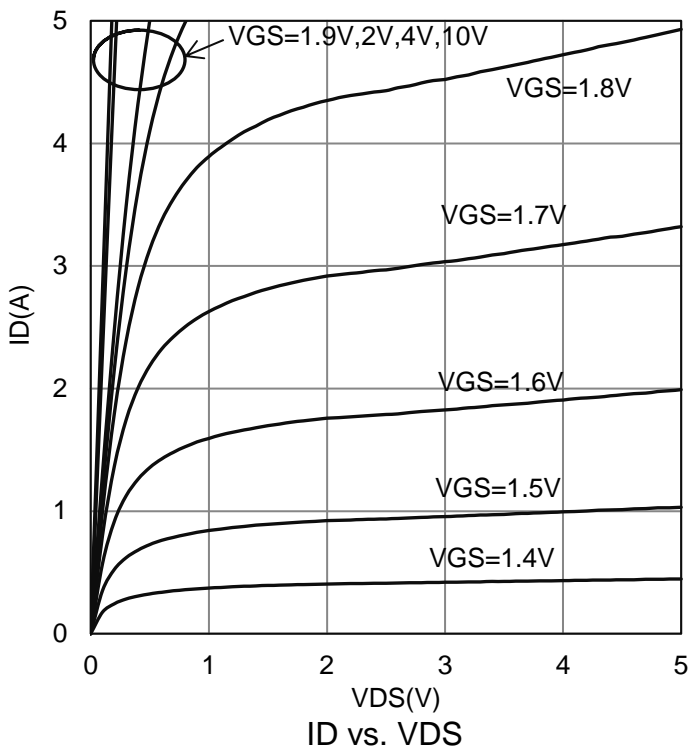

7. ELECTRICAL CHARACTERISTICS CURVES

7.ELECTRICAL CHARACTERISTICS CURVES(Con.)

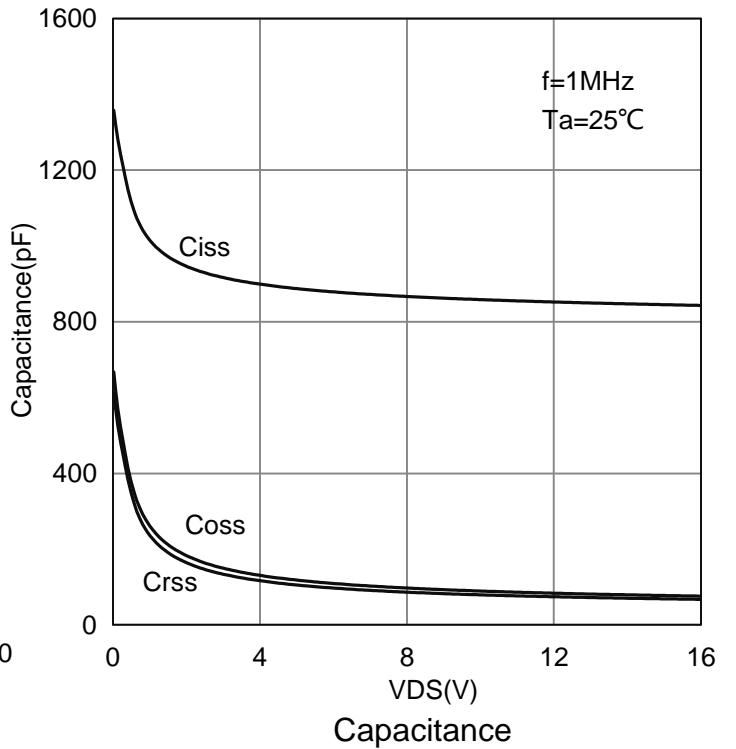
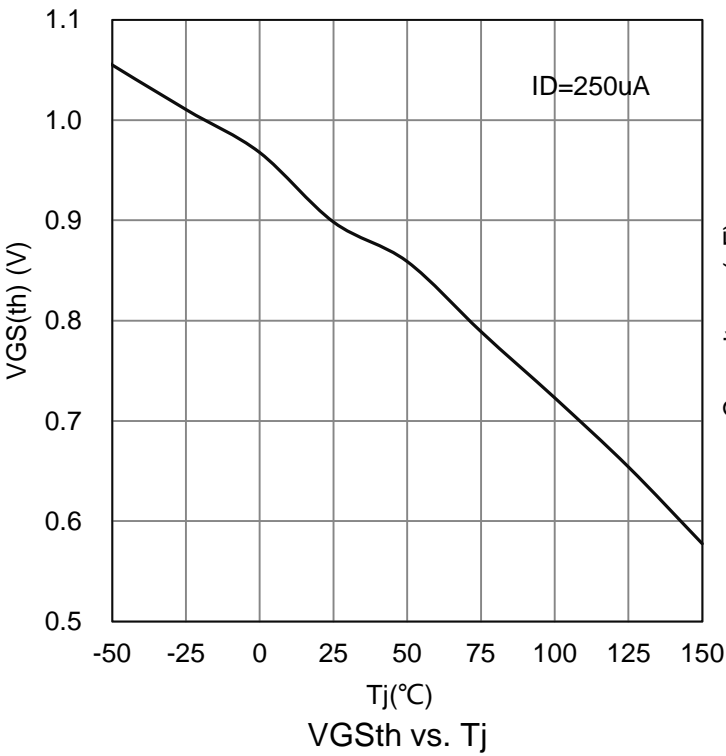
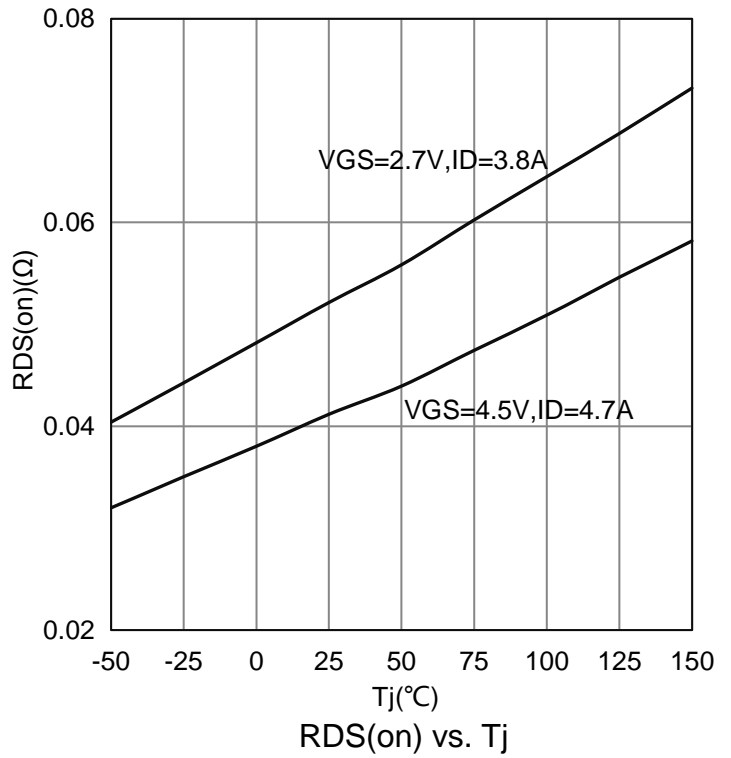
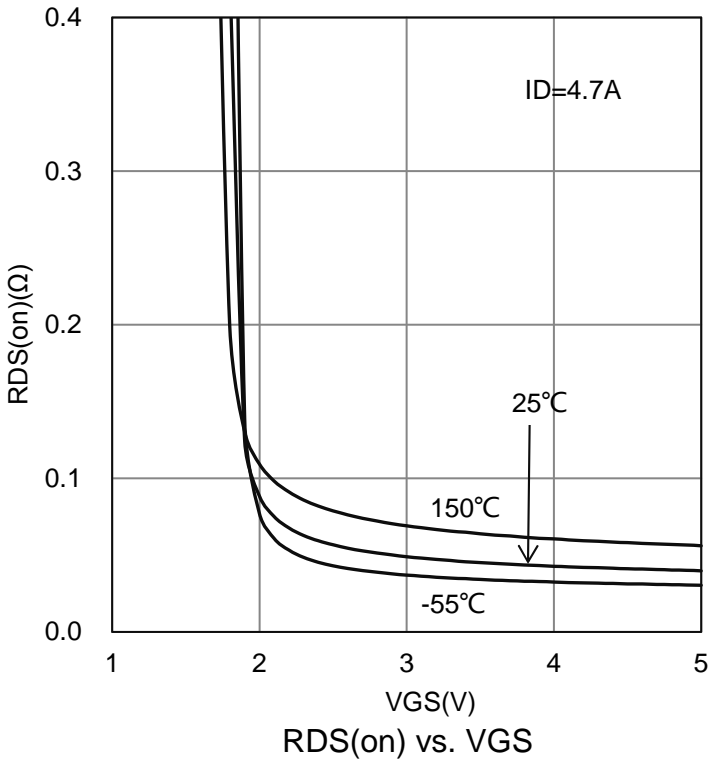

8. OUTLINE AND DIMENSIONS

Notes:

1. DIMENSIONING AND TOLERANCING PER ANSI Y14.5M, 1982.
2. CONTROLLING DIMENSION: MILLIMETERS.
3. MAXIMUM LEAD THICKNESS INCLUDES LEAD FINISH. MINIMUM LEAD THICKNESS IS THE MINIMUM THICKNESS OF BASE MATERIAL.
4. DIMENSIONS D AND E DO NOT INCLUDE MOLD FLASH, PROTRUSIONS OR GATE BURRS.

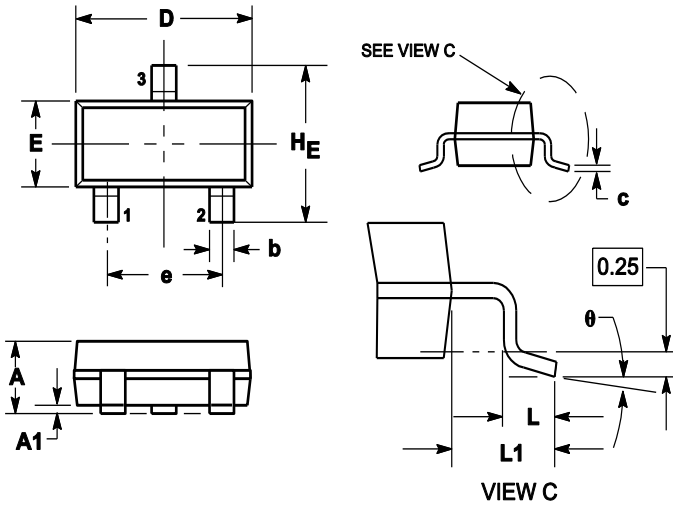

DIM	MILLIMETERS			INCHES		
	MIN	NOM	MAX	MIN	NOM	MAX
A	0.89	1	1.11	0.035	0.04	0.044
A1	0.01	0.06	0.1	0.001	0.002	0.004
b	0.37	0.44	0.5	0.015	0.018	0.02
c	0.09	0.13	0.18	0.003	0.005	0.007
D	2.80	2.9	3.04	0.11	0.114	0.12
E	1.20	1.3	1.4	0.047	0.051	0.055
e	1.78	1.9	2.04	0.07	0.075	0.081
L	0.10	0.2	0.3	0.004	0.008	0.012
L1	0.35	0.54	0.69	0.014	0.021	0.029
HE	2.10	2.4	2.64	0.083	0.094	0.104
theta	0°	---	10°	0°	---	10°

9. SOLDERING FOOTPRINT
